

ES Series Operating Manual and User Guide

CW Broadcast



CW Broadcast
111 N. Vista Rd, Ste 3E
Spokane Valley, WA 99212
Phone—(509) 290-6652 / (888) 889-2958

World Wide Web—<http://www.cwbroadcast.com>

Version 2.0— Aug 2022

™
CW Broadcast
CircuitWerkes reserves the right to revise and change any and
all information included in this document.

Copyright © 2022 CircuitWerkes, Inc.

ALL RIGHTS RESERVED. No part of this publication may be reproduced, transmitted, transcribed, stored in a retrieval system, or translated into any language in any form by any means for any purpose other than the purchaser's personal use without the permission of CircuitWerkes, Inc.

The information in this publication has been checked and is believed to be accurate. However, CircuitWerkes, Inc. assumes no responsibility for inaccuracies. We retain the right to make changes to this publication at any time without prior notice. CircuitWerkes, Inc. does not assume any liability arising from the application or use of this publication or the product(s) described herein.

RESTRICTED RIGHTS LEGEND: Use, duplication, or disclosure by the United States Government is subject to the restrictions set forth in DFARS 252.227-7013 (c)(1)(ii) and FAR 52.227-19.

This manual is for these CW Broadcast transmitters:
FM300ES, FM500ES, and FM1050ES

Operating Voltage Requirements:
FM300ES and FM500ES are Single Phase 110VAC Transmitters

The PTEK FM1050ES is a Dual Phase 110VAC device, more commonly referred to as 220VAC

Warranty Service:

ES Series transmitters are warranted for a period of 42 months from date of purchase. During the warranty period we will repair or replace the transmitter, at our sole discretion. No refunds will be issued after 90 days. Contact customer service to obtain an RMA for your product.

This warranty does not cover acts of God such as lightning. Damage caused by misuse or shipping is excluded from the warranty. CW Broadcast will not warranty the product due to misuse, accident, neglect, and improper installation or operation, or abuse such as immersion in water or direct exposure to the natural elements.

The Limited Warranty covers parts and labor to the original purchaser as outlined on purchase invoice for use in the United States of America. Customer is responsible for shipping to us. We will prepay ground shipping back to the customer.

---These transmitters are not recommended for use as a replacement IPA---

Proper installation includes A/C line surge suppression, lightning protection and proper grounding of the entire transmitter, and any other recommendations designated in this Operating Manual.

CW Broadcast
Customer Service Manager
111 N Vista Rd, Suite 3E
Spokane Valley, WA 99212
(509) 290-6652 / (888) 889-2958

Safety Instructions

To maximize user safety and ensure correct device operation, all instructions contained in this section should be read carefully.



Caution: It is important that the user observe all warnings and instructions that are on the device and contained in this manual.

Before Applying Power



Warning: DO NOT OPERATE IN AN EXPLOSIVE ATMOSPHERE

Operation of the transmitter in the presence of flammable gases or fumes can endanger persons proximate to the site of operation.

Verify that the line voltage is 115 to 230 VAC, single phase.

Ground the Exciter



Caution: NO NOT REMOVE THE TRANSMITTER'S COVER
Removal of the exciter cover will invalidate the Warranty.
Component replacement and internal adjustments must be made only by CW Broadcast qualified service personnel.

To minimize shock hazard, the exciter chassis must be connected to an electrical ground, the exciter must be connected to the AC power mains through a three-conductor power cable, with the third wire connected to an electrical ground (safety ground) at the power outlet. Any interruption of the protective (grounding) conductor or disconnection of the protective earth terminal will cause a potential shock hazard that could result in personal injury. If the exciter is to be energized by any other source be certain that the chassis is connected to a separate safety ground.

Fuses

Only fuses with the same required current, voltage rating, and specified type (normal blow, time delay, etc.) should be used. Do not use repaired fuses or short-circuited fuseholders. To do so could cause a shock or fire hazard.

Output Connector



Warning: The type-N output connector carries dangerously high RF voltages that present shock and burn hazards. Never operate the transmitter without properly terminating the output connector in either an adequately rated load or antenna.

Electrostatic Discharge (ESD)

A sudden discharge of electrostatic electricity can destroy static-sensitive devices or micro-circuitry. Proper packaging and grounding techniques are necessary precautions to prevent damage. Always take industry-standard precautions.

Grounding Methods

Guard against electrostatic damage at workstations by following these steps:

1. Cover workstations with approved anti-static material. Provide a wrist strap connected to a work surface and properly grounded tools and equipment.
 2. Use anti-static mats, heel straps, or air ionizers to give added protection.
 3. Handle electrostatic-sensitive components, boards, and assemblies by the case or the PCB edge.
 4. Avoid contact with pins, leads, or circuitry.
 5. Turn off power and input signals before inserting and removing connectors or test equipment.
 6. Keep the work area free of non-conductive materials such as ordinary plastic assembly aids and Styrofoam.
 7. Use field service tools, such as cutters, screwdrivers, and vacuums that are conductive.
-

General Safety Rules

- The device must be used in accordance with the instructions for use.
 - Electrical installations in the room must correspond to the requirements of respective regulations.
 - Take care that there are no cables, particularly mains cables, in areas where persons can trip over them.
 - Do not use a mains connection in sockets shared by a number of other power consumers. Do not use an extension cable.
 - Only use the mains cable supplied.
 - The unit is completely disconnected from the power source only when the power cord is disconnected from the power source. Therefore the power cord and its connectors must always remain easily accessible.
 - Do not set up the device in the proximity of heat sources or in a damp location. Make sure the device has adequate ventilation.
 - All plugs on the connection cables must be screwed or locked to the chassis housing.
 - The device is designed to be used in horizontal position only.
 - The device is no longer safe to operate when the device has visible damage or the device no longer functions.
 - In case of system malfunction or visible damage to the FM 500ES, the device must be shut down and secured against unintentional operation.
 - Repairs may only be carried out by a person authorized by CircuitWerkes, Inc..
 - If extensions are made to the transmitter, the legal stipulations and the device specifications must be observed.
 - The transmitter must be switched off and the line cord disconnected from the AC source when removing the top cover.
-

Table of Contents

Limited Warranty	iii
Warranty Service	iii
Safety Instructions	iv
Prefacexiii
Website Information	xiv
Your Comments are Welcome	xiv
Notes, Cautions, Warnings, and Sidebars	xv
1. Overview and Specifications.....	1-1
1.1 Overview.....	1-1
1.2 Specifications.....	1-4
1.2.1 General	1-4
1.2.2 Electrical	1-5
1.2.2.1 System Power	1-5
1.2.3 Environmental	1-6
1.2.3.1 Shock	1-6
1.2.3.2 Electrostatic Discharge	1-6
1.2.3.3 Noise Level	1-6
1.3 Packaging and Shipping	1-7
1.3.1 Rack-Mount Slides (Optional)	1-7
2. Installation.....	2-1
2.1 Installation Procedures.....	2-1
2.2 Removing the Protective Top Cover.....	2-2
2.3 Removing a Power Supply.....	2-2
2.4 Changing the Fuse	2-5
2.5 Cleaning the Air Filter	2-6

2.6Rack Mounts	2-7
2.6.1Mounting Brackets	2-7
2.6.2Rack-Mount Slides (Optional)	2-8
3.Operation	3-1
3.1Set Up the System	3-1
3.2Power Up the System	3-2
3.3Getting Started	3-4
3.3.1Startup Sequence	3-4
3.3.2Changing the Stereo Encoder	3-5
3.3.3Audio	3-6
3.3.4Final Check	3-7
3.4Additional Adjustments	3-9
3.5Tune Up the Antenna	3-10
3.6Power Down the System	3-10
Appendix A.Connector Pinouts	A-1
A.1Accessory Port	A-1
Appendix B.Rack-Mount Slide Installation	B-1
Index	Index-1
Reader Comment Card	

List of Figures

Figure 1-1	Transmitter FM Stereo Broadcast Transmitter.....	1-1
Figure 1-2	Transmitter System Block Diagram	1-2
Figure 1-3	Transmitter Front Panel.....	1-2
Figure 1-4	Transmitter Open Top View (A) and Rear Panel (B).....	1-3
Figure 2-1	Transmitter Right-Side Top Cover Phillips Screws.....	2-2
Figure 2-2	Remove the Four Phillips Screws from the Power Supply Mounting Plate 2-3	
Figure 2-3	Disconnect Five Wires before Removing Power Supplies.....	2-4
Figure 2-4	Remove Fuse Holder to Remove Fuse.....	2-5
Figure 2-5	Remove the Front Panel Screws to Access the Air Filter.....	2-6
Figure 2-6	Remove the Exposed Air Filter.....	2-6
Figure 2-7	Make Sure the Air Vent Hole s are Unobstructed.....	2-6
Figure 2-8	Left and Right Rack-Mount Brackets.....	2-7
Figure 3-1	FMx00ES Rear-Panel Connectors.....	3-2
Figure 3-2	Plug the Power Cord into the Transmitter AC Power Socket.....	3-3
Figure 3-3	After Power has been Applied to the FM500ES, it enters Standby mode.....	3-3
Figure 3-4	After the OPERATE Key is Pressed, the Startup Sequence Begins.....	3-4
Figure 3-5	Stereo Encoder Can be Changed Through the LCD Display.....	3-5
Figure 3-6	Press the RAISE or LOWER key to Change the LCD Display.....	3-5
Figure 3-7	The Deviation Screen is Displayed through the FUNCTION Key.....	3-6
Figure 3-8	Audio Gain Can be Adjusted Through the LCD Display.....	3-6
Figure 3-9	Press the FUNCTION Key to read Frequency.....	3-7
Figure 3-10	Press the FUNCTION Key to read Audio Gain.....	3-7
Figure 3-11	Press the FUNCTION Key to read VOLTS & AMPS.....	3-8
Figure 3-12	Press the FUNCTION Key to read Forward & Reverse Power.....	3-8
Figure 3-13	Press the FUNCTION Key to read Deviation.....	3-8
Figure 3-14	Press LOWER/RAISE/FUNCTION Keys Simultaneously.....	3-9

Figure 3-15	TO COME.....	3-9
Figure 3-16	TO COME.....	3-10
Figure 3-17	TO COME.....	3-10
Figure A-1	Accessory Port Pinout.....	A-1
Figure B-1	Transmitter Right-Side Rack-Mount Slide Holes.....	B-2
Figure B-1	Transmitter FM Stereo Broadcast Transmitter Rack-Mount Slide Installation B-3	
Figure B-2	CLB-203 Rack-Mount Slide with Quick Disconnect.....	B-4

List of Tables

Table 1-1	Transmitter General Specifications.....	1-4
Table 1-2	Transmitter Electrical Specifications.....	1-5
Table 1-3	Typical Noise Levels of the Transmitter.....	1-6
Table A-1	Accessory Port Pinout Signal Descriptions.....	A-2

Preface

This document, ES Operating Manual and User Guide, provides instructions on how to install, configure, power up, and perform diagnostics on the 50, 150, 300 and 500 Watt CW Broadcast ES FM Broadcast Transmitter (see photo below), an easy-to-use and versatile system that can be used in either stand-alone or backup mode. The information contained within is intended for an experienced system operator with a knowledge of high-performance broadcast transmission systems. The 3RU-high (3.5") FM300-500ES designed to fit a standard is 19" rack Optional rack-mount slides are also available.



DDS FM Stereo Broadcast Transmitter

Key features of the ES FM Stereo Broadcast Transmitter include:

- Totally solid-state no-tune construction
- Wide input range from 88 to 264 VAC
- 2-year warranty on all parts and labor
- Built-in field-programmable FSK ID for translator use
- Remote-control interface
- Optional built-in stereo encoder
- Rugged design withstands up to 5G forces and 50°C
- Meets or exceeds all FCC and CCIR standards
- Designed and manufactured in the United States
- Direct Digital Synthesis Exciter for superb sonic purity

All transmitters feature Direct Digital Synthesis (DDS) instead of older PLL and varacter diode technology. All units incorporate over-temperature protection & VSWR foldback to automatically reduce power output to safe operating levels.

Switch-mode power supplies provide consistent performance even when there are frequent power outages and voltage fluctuations that make stressful demands of power dependence. An overview and specifications of the ES FM Stereo Broadcast Transmitters is given in Chapter 1, "Overview and Specifications", of this manual.

Website Information

CW Broadcast product information may be accessed on the World Wide Web by browsing the website <http://www.cwbroadcast.com>

Your Comments are Welcome

We are interested in improving our documentation and welcome your comments and suggestions. You can email your comments to us at support@cwbroadcast.com Please include the document part number in the subject line of your email.

Notes, Cautions, Warnings, and Sidebars

The following icons and formatted text are included in this document for the reasons described:



Note: A note provides additional information concerning the procedure or action being described.



Caution: A caution describes a procedure or action that may result in injury to the operator or equipment. This may involve—but not restricted to—heavy equipment or sharp objects. To reduce the risk, follow the instructions accompanying this symbol.



Warning: A warning describes a procedure or action that may cause injury to the operator or equipment as a result of hazardous voltages. To reduce the risk of electrical shock and danger, follow the instructions accompanying this symbol.



Sidebar: A “sidebar” adds detail to the section within which it is placed, but is not absolutely vital to the description or procedure of the section.

Overview and Specifications

1.1 Overview

The 3RU-high (5.25") ES Series FM Stereo Broadcast Transmitter is designed to fit a standard 19" rack and is provided with rack-mount left and right brackets and handles. Optional rack-mount slides are also available. The ES Series are rugged enough to withstand extreme shock (up to 5G), temperature (up to 50°C), and EMI such as that associated with broadcasting from remote rugged environments. (see Figure 1-1; a block diagram is given in Figure 1-2, page 1-2). The ES Series supports Mono, Wideband Stereo (left and right) and SCA inputs, ideal for a variety of commercial and dedicated stereo broadcast transmission applications.



Figure 1-1. CW Broadcast FM Stereo Broadcast Transmitter

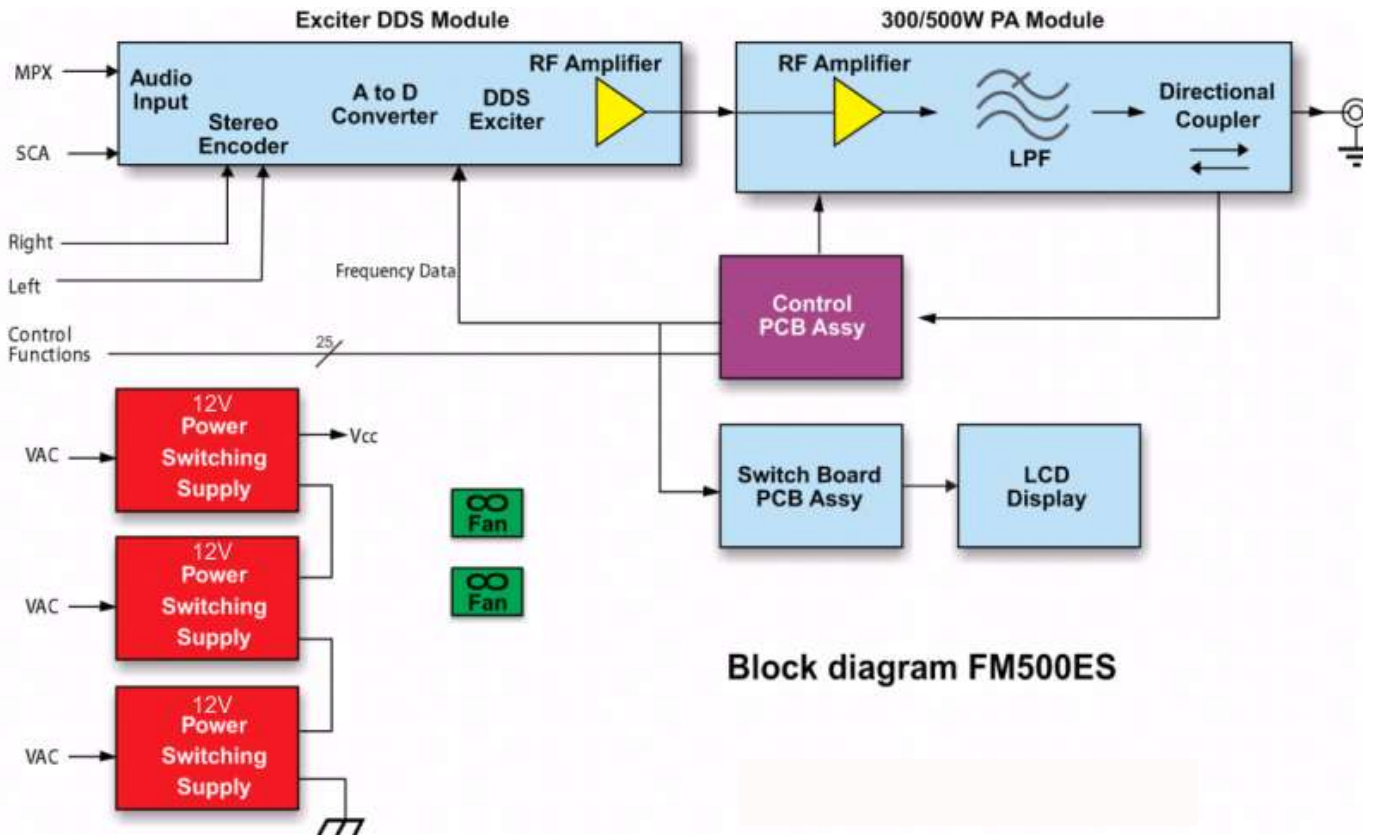
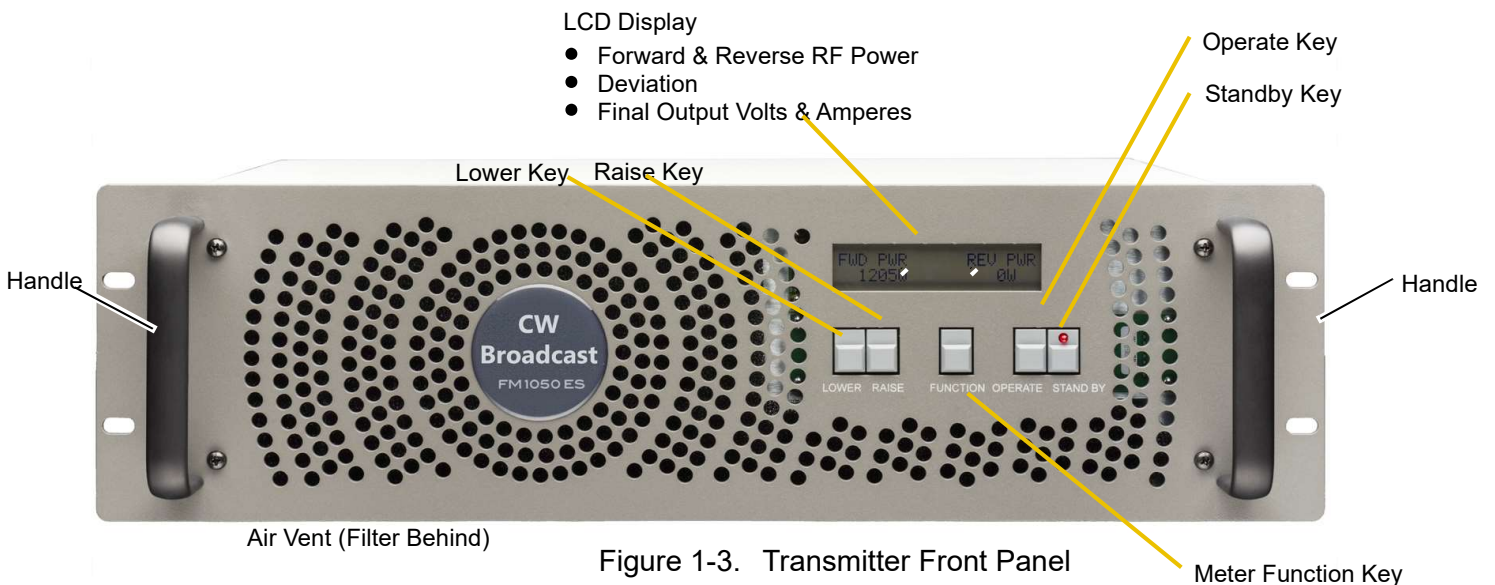

Figure 1-2. Transmitter System Block Diagram

The Transmitter is designed within a 3RU-high (5.25”) form-factor that is 13.75” (34.9 cm) deep (including the frontpanel and rear protective flanges; the chassis body itself is 13” deep) and 17” (43.2 cm) wide (19” including the frontpanel to fit a standard-size rack).

Features on the Transmitter front panel are shown in Figure 1-3



Major internal components of the Transmitter can be seen in the open top view (cover removed) displayed in Figure 1-4 (A). Features on the Transmitter rear panel are shown in Figure 1-4 (B).

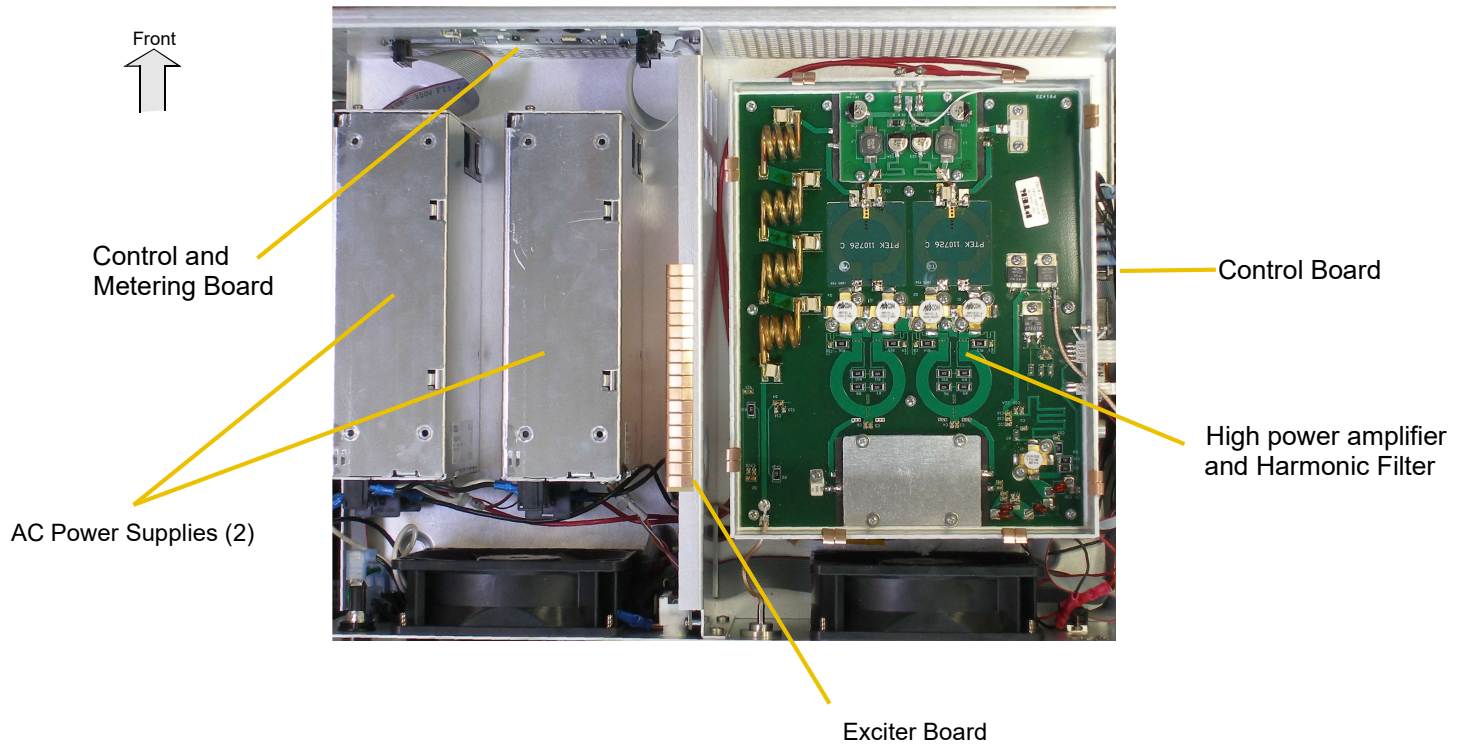

A Transmitter Top View (Cover Off)

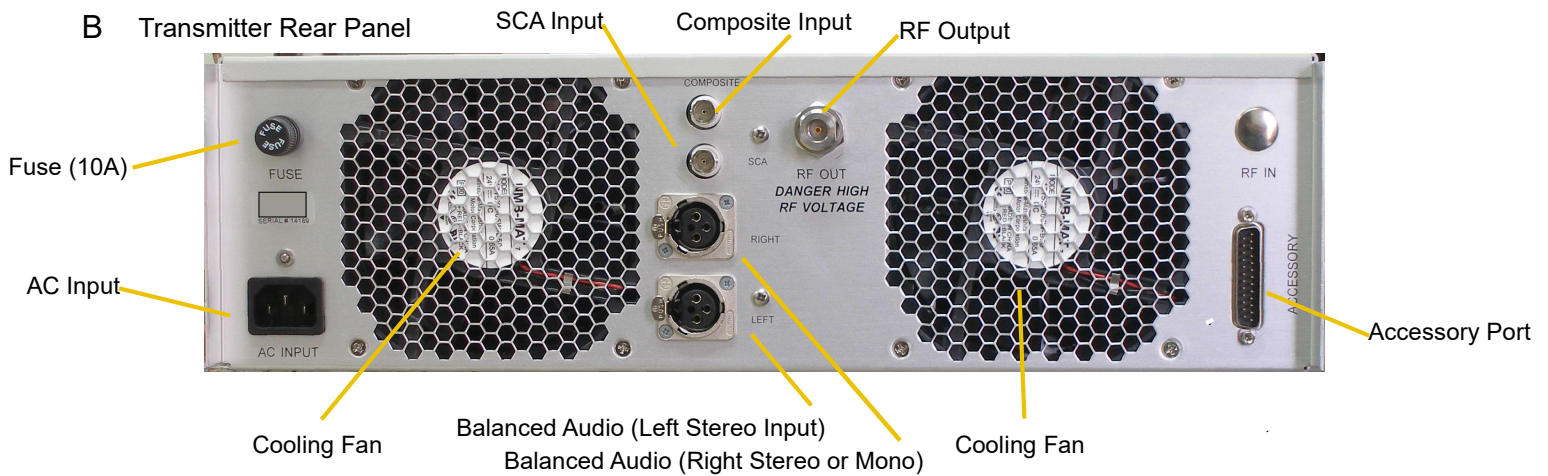

Figure 1-4. Transmitter Open Top View (A) and Rear Panel (B)

1.2 Specifications

1.2.1 General

Table 1-1 lists general specifications for the Transmitter.

Table 1-1. Transmitter General Specifications

Parameter	Description
Dimensions	<ul style="list-style-type: none">ζ 5.25" (3RU) highζ 17" (43.2 cm) wide (19" including the front panel)ζ 13.75" (34.9 cm) deep (including the front panel and rear protective flanges; the chassis body itself is 13" deep)
Weight	<p>Total shipping weight is under 33.5 pounds (15.2 kg) and includes the following:</p> <ul style="list-style-type: none">ζ Chassis = under 24 pounds (10.9 kg), including two AC power suppliesζ Add 8.5 pounds (4 kg) for the shipping container and one AC power cordζ The manual and associated shipping paperwork weigh approximately 1 lb (0.5 kg)
19" Rack-Mountable with Slide capability	<ul style="list-style-type: none">ζ Left and right rack-mount tabs and handles are attached directly to the chassis. Rack-mount slides are optional
Temperature Operating: Non-Operating:	<ul style="list-style-type: none">ζ 0°C to +50°Cζ -40°C to +70°C
Relative Humidity Operating: Non-Operating:	<ul style="list-style-type: none">ζ 8% to 90% non-condensingζ 5% to 95% non-condensing
Maximum Wet Bulb Operating: Non-Operating:	<ul style="list-style-type: none">ζ 27°C, non-condensingζ 35°C, non-condensing
Altitude Operating: Non-Operating	<ul style="list-style-type: none">ζ 0 to 10,000 feet above sea levelζ 0 to 40,000 feet above sea level

1.2.2 Electrical

Table 1-2 lists the electrical specifications for the Transmitter.

Table 1-2. Transmitter Electrical Specifications

Parameter	Description
Frequency Range	ζ 87.7 MHz to 108 MHz
Audio Input Impedance	ζ 600 ohms
Audio Input Level (Composite)	ζ -10 dBm
Audio Input Level R & L Stereo Encoder (optional)z	-10 dBm
Frequency Response (Composite)	ζ 20 Hz to 15(90) KHz
Pre-Emphasis	ζ 50 or 75 uS
Harmonic Distortion	ζ < 0.25% max
Signal-to-Noise Ratio	ζ > 80 dB rms
RF Output Impedance	ζ 50 ohms
Output Connector	ζ N-type female
RF Power Output	ζ 550 W (330W 300ES 165W 150ES and 55W 50ES)
Harmonic Attenuation	ζ < -70 dB
Power Requirements	ζ 88–264 VAC, internally fused
Fuse	ζ MDA 10 Amperes, 250 Volts AC

1.2.2.1 System Power

The Transmitter, Fm300 and FM150 uses two AC power supplies; FM50ES uses one. Each AC power supply has is auto-ranging single-phase AC input from a 88 to 264 VAC (47 to 63 Hertz)

1.2.3 Environmental

1.2.3.1 Shock

The Transmitter is designed to survive an elevated shock environment. All structural components are welded together, enabling the system to survive a maximum 3-axis shock load of 5G at 20-msec duration.

1.2.3.2 Electrostatic Discharge

The Transmitter is designed to tolerate electrostatic pulses up to 15 kilovolts (KV) with no impact on system operation.

1.2.3.3 Noise Level

Typical noise levels emitted by the Transmitter are outlined in Table 1-3. The chassis is installed with two 60-mm fans mounted side-by-side at the rear of the system. In addition, each AC power supply has its own cooling fan.

Table 1-3. Typical Noise Levels of the Transmitter

Measured at:	1 Meter	2 Meters
Front	66.24 dB	57.57 dB
Rear	61.53 dB	57.93 dB

1.3 Packaging and Shipping

The Transmitter FM Stereo Broadcast Transmitter is packaged in a reusable shipping container. Approximate weight of an empty container and one (1) AC power cord is 9 pounds (4 kg).

The approximate weight of a Transmitter (installed with two power supplies) is under 15 pounds (6.8 kg).

The approximate weight of a manual and associated shipping paperwork is one (1) pound (0.5 kg).

Therefore, both the shipping container and a fully installed Transmitter including power cord, manual, and associated paperwork, weigh under 25 pounds (11.3 kg).

1.3.1 Rack-Mount Slides (Optional)

Rack-Mount slides (optional) can be installed on each side of the Transmitter for the purpose of sliding the unit easily in and out of a 19" rack using the convenient front handles. Rack-mount slides should be ordered at the time of purchase.

To learn how to install rack-mount slides, refer to Appendix B, "Rack-Mount Slide Installation", on page B-1.

Installation Section

Chapter 2

Installation

2.1 Installation Procedures



Caution: Use industry-standard ESD grounding techniques when handling all components. Wear an antistatic wrist strap and use an ESD-protected mat. Store ESD-sensitive components in antistatic bags before placing them on any surface. Handle all IC cards by the front panel or edges only.

There are no operator serviceable parts inside the transmitter, therefore, replacement, inspection, or adjustment of internal components within the Transmitter requires service by an approved technician only. **DO NOT REMOVE THE TOP PROTECTIVE COVER OF THE Transmitter CHASSIS** (see following Warning).



Warning: Removal of the top protective cover of the Transmitter by anyone other than an authorized CW Broadcast technician will void the product warranty.

2.2 Removing the Protective Top Cover



Warning: Make sure that the AC power cord is removed from the AC input connector on the rear of the Transmitter before removing the protective top cover.

Open the Transmitter FM Stereo Broadcast Transmitter as follows:

1. Remove the protective top cover of the Transmitter by loosening the two Phillips screws on each side of the chassis (see Figure 2-1).



Figure 2-1. Transmitter Right-Side Top Cover Phillips Screws

2. Store the cover and screws in a safe place until replaced.
-

2.4 Changing the Fuse

The Transmitter FM Stereo Broadcast Transmitter contains a fuse rated at MDA 10A, 250V that is installed within an easily removed fuse holder (see Figure 2-4).

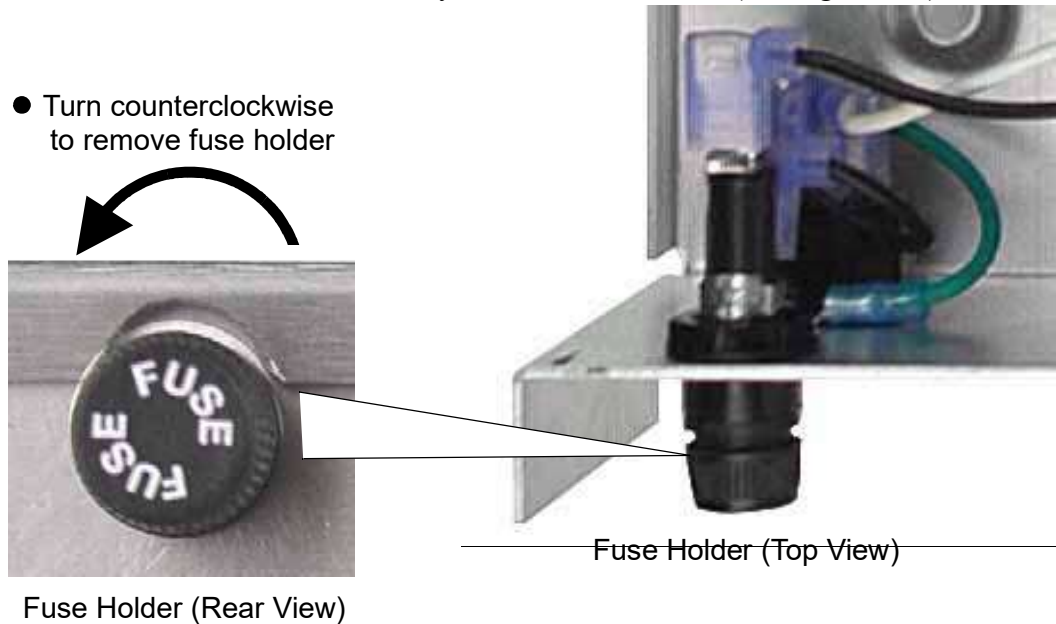

Figure 2-4. Remove Fuse Holder to Remove Fuse

To remove the fuse, turn the cap of the fuse holder (located at the rear of the chassis) counterclockwise until it can be removed from the fuse holder body. Pull the fuse from the cap and replace it with a fuse of the same value.

2.5 Cleaning the Air Filter

Accessing the air filter requires removing the front panel of the Transmitter.

1. Remove the 4 Phillips screws on the Transmitter front panel (see Figure 2-5)



Figure 2-5. Remove the Front Panel Screws to Access the Air Filter

2. Remove the air filter (see Figure 2-6), then carefully wash it with mild soap and water.



Figure 2-6. Remove the Exposed Air Filter

3. Check that the exposed air vent holes are unobstructed.

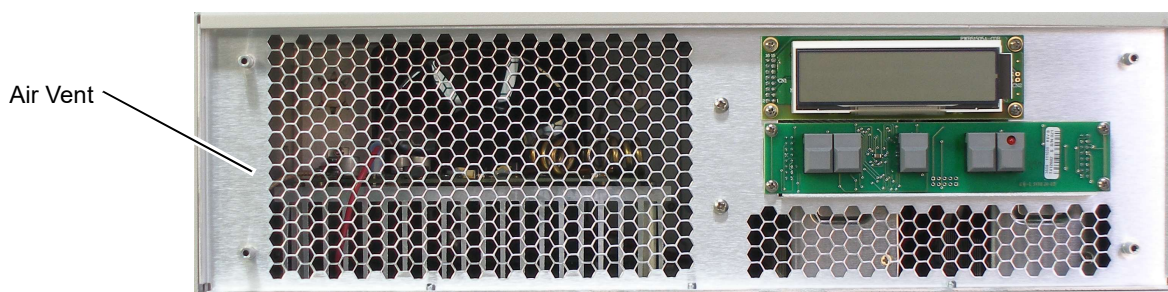

Figure 2-7. Make Sure the Air Vent Holes are Unobstructed

4. After the air filter has been dried, replace it and the front panel. Make sure the front panel screws are fully tightened.

2.6 Rack Mounts

Rack-mount brackets (or flanges)—which are built into the chassis and therefore not removable—are used to secure the Transmitter chassis to a 19” rack.

Rack-mount slides are used to pull the Transmitter away from the rack for easier access.

2.6.1 Mounting Brackets

Use the following steps to secure a Transmitter chassis to a 19” rack.

1. With the help of a second person, carefully insert the Transmitter chassis into the 19” rack (see Figure 2-8).



Figure 2-8. Left and Right Rack-Mount Brackets

2. Using four 10-32 screws with corresponding lock washers and nuts, attach the Transmitter chassis to the 19” rack through the four mounting holes of the mounting brackets.



Caution: Make sure to tighten each mounting screw to assure that the Transmitter chassis is firmly installed onto the 19” rack.

2.6.2 Rack-Mount Slides (Optional)

Rack-Mount Slides can be mounted on each side of the Transmitter FM Stereo Broadcast Transmitter for the purpose of sliding the unit in and out of a rack. Mounting slides are optional and should be ordered at the time your system is purchased.

To learn how to install rack-mount slides, refer to Appendix B, “Rack-Mount Slide Installation”.



Caution: Any screws used to mount a slide to a Transmitter chassis must not exceed a length of 3/8” to prevent excessive penetration of the chassis.

Operation

This chapter describes:

- How to set up the Transmitter system to begin operation
- How to turn the Transmitter on and off
- How to monitor and change the operational settings of the Transmitter

3.1 Set Up the System

To successfully operate the FM Stereo Broadcast Transmitter, an antenna (or power amplifier) and an audio source must first be connected to the system, as outlined in the following steps:

1. Connect the antenna or power amplifier input to the RF output connector on the rear panel of the Transmitter (see Figure3-1 on page3-2).
2. Connect the audio input to one of the following connectors the rear panel:
 - Composite Input (ensure the Stereo encoder is disabled)
 - Balanced Mono Input
 - Balanced Stereo Left and Right (if equipped with stereo encoder)

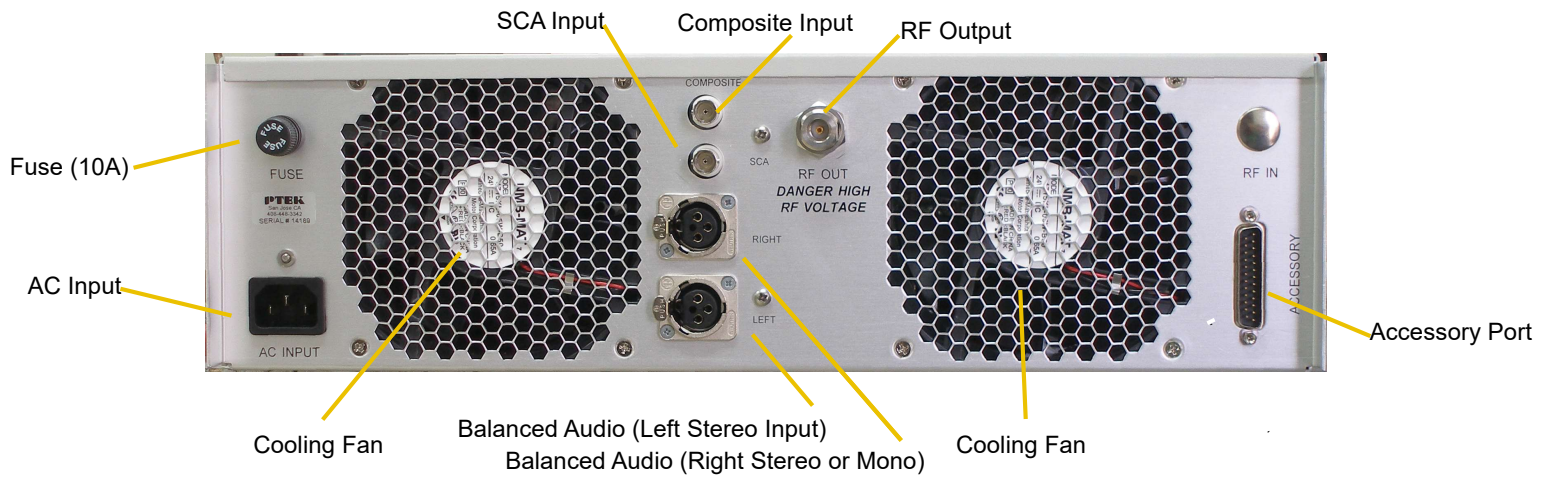

Figure 3-1. Transmitter Rear-Panel Connectors

3.2 Power Up the System

1. On the rear of the Transmitter, plug an AC power cord (shipped with each unit) into the AC power socket (see Figure 3-2 on page 3-3).
2. Plug the other end of the AC power cord into a “live” AC outlet.



Note: There is no On/Off switch (key) on the Transmitter.

As soon as power is introduced to the system through an AC power cord attached to a “live AC outlet, if the system was powered off while in Standby mode, the system will again enter **Standby** mode and the light on the **STANDBY** key on the front of the Transmitter will turn red

If the system was powered off while not in Standby mode, it will begin the startup sequence described in the section “Startup Sequence” on page 3-4.

3. Make sure the **STANDBY** key on the front of the Transmitter has turned red (or the system has begun the startup sequence), thus assuring that the system has powered on (see Figure 3-3, page 3-3).

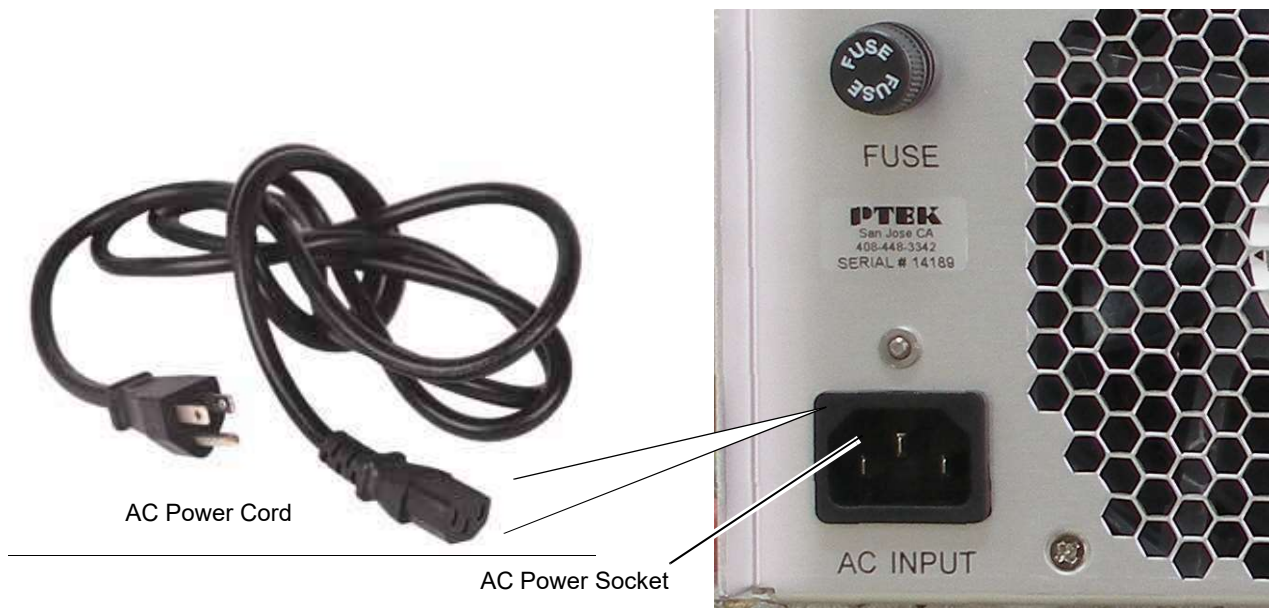
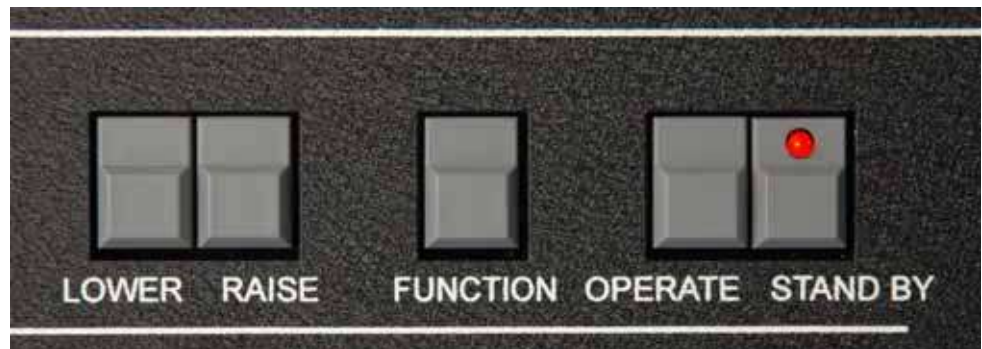

Figure 3-2. Plug the Power Cord into the Transmitter AC Power Socket



A Before power is applied to the system, the STANDBY key LED is off



B After power is applied to the system, the STANDBY key LED turns red

Figure 3-3. After Power has been Applied to the Transmitter, it enters Standby mode

3.3 Getting Started

3.3.1 Startup Sequence

1. Press the OPERATE key on the front of the Transmitter.
2. After the OPERATE key is enabled, the LED display will show the initialization sequence and display the screens—in order—shown in Figure 3-4

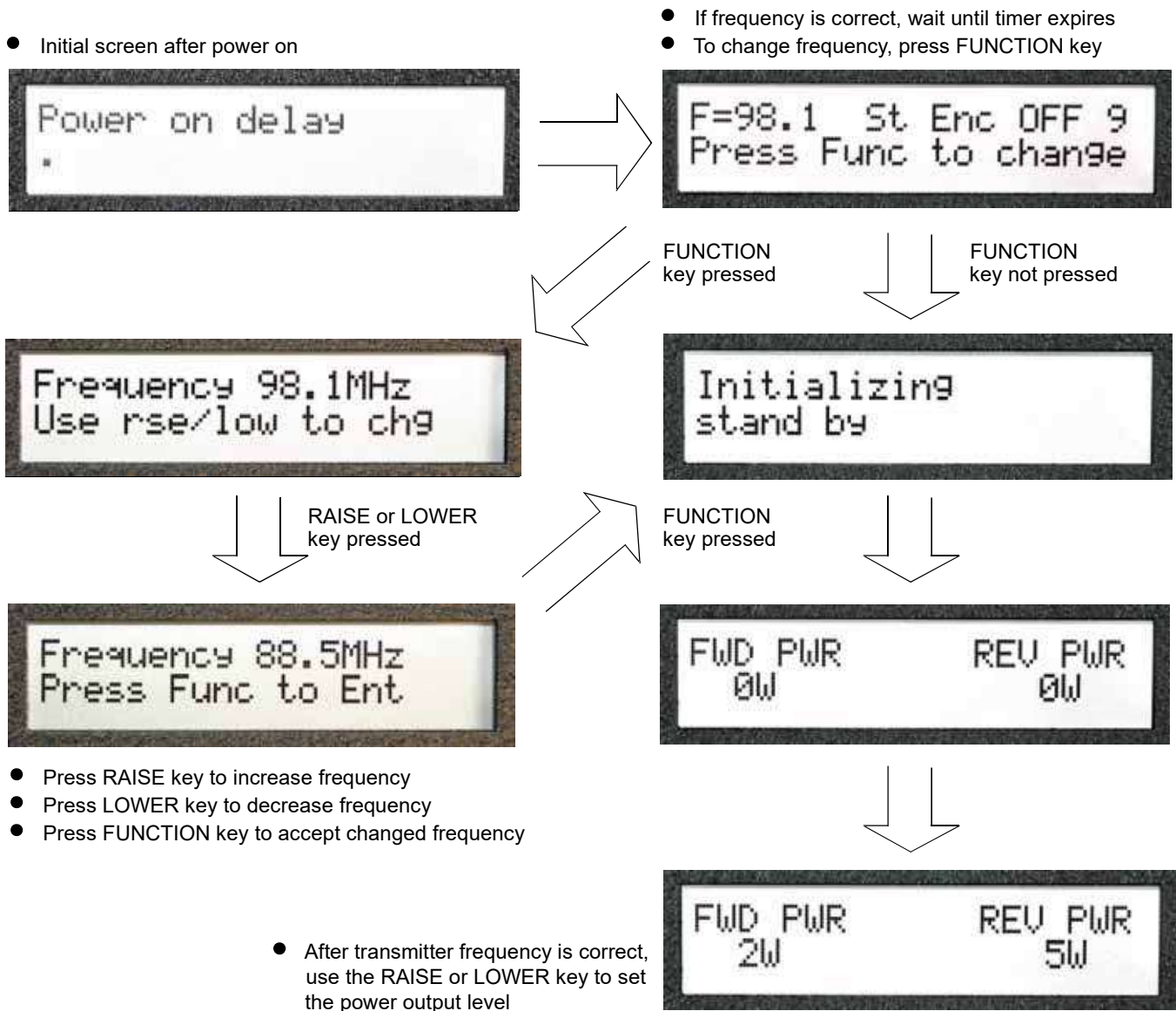

Figure 3-4. After the OPERATE Key is Pressed, the Startup Sequence Begins

3.3.2 Changing the Stereo Encoder

After changing the frequency in the start up sequence (see previous page), you have the option of changing the Stereo Encoder setting:

1. If the LCD screen displays the desired setting (Stereo Encoder OFF or ON), press the FUNCTION key to accept the setting (see Figure 3-5).

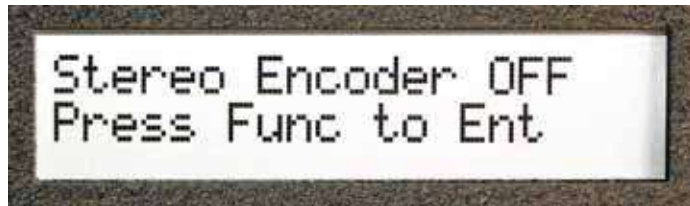

Figure 3-5. Stereo Encoder Can be Changed Through the LCD Display

2. To change the Stereo Encoder setting, press the RAISE or LOWER key, which will result in the alternate setting (see Figure 3-6).

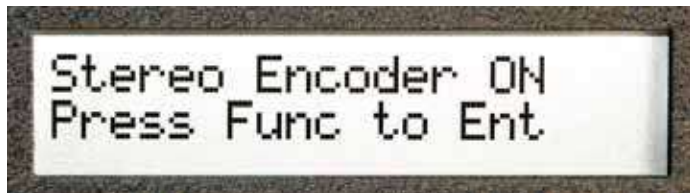
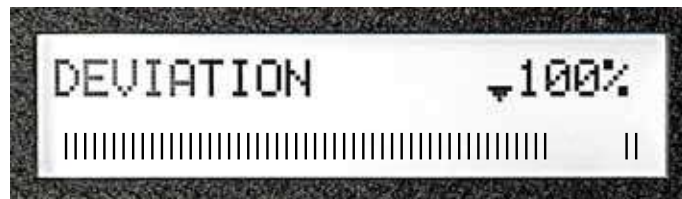

Figure 3-6. Press the RAISE or LOWER key to Change the LCD Display

3.3.3 Audio

Audio levels for the Transmitter have already been set and should not need to be

changed. Deviation can be checked by pressing the FUNCTION key until the appropriate LCD screen is reached (see Figure 3-7).



reached. Figure 3-7. The Deviation Screen is Displayed through the FUNCTION Key

When the LCD display is in DEVIATION mode, the maximum deviation should occasionally reach 100% (indicated by the thick bar). If the 100% level is never reached or exceeds 100%, the level needs to be adjusted.

The output level from the audio source should be adjusted to give a peak deviation of 75 kHz (as described above).

If the correct deviation cannot be obtained, the audio gain can be raised or lowered by pressing the FUNCTION key until the appropriate LCD screen is reached (see Figure 3-8).

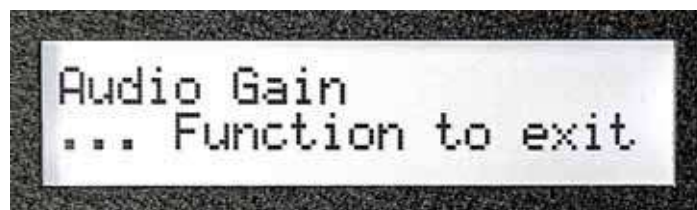

Figure 3-8. Audio Gain Can be Adjusted Through the LCD Display

When the AUDIO GAIN screen appears, the value may be raised by pressing the RAISE key or lowered by pressing the LOWER key until the desired deviation is

3.3.4 Final Check

Pressing the FUNCTION key rotates the LCD display through the following screens:



Note: At each screen, pressing the LOWER or RAISE key changes the output power only. PA VOLTS and PA AMPS is another way of indicating the power output, accomplished by multiplying the voltage by the amperage (current), then multiplying the result by the efficiency.

Readings should be recorded weekly to keep track of changes, which may indicate developing problems such as antenna or coax deterioration.

1. After pressing the FUNCTION key on the front of the Transmitter, the operating frequency will appear on the LCD display (see Figure 3-9).

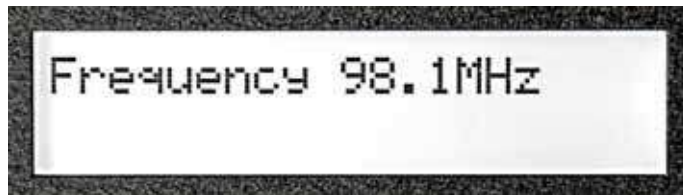

Figure 3-9. Press the FUNCTION Key to read Frequency

2. Pressing the FUNCTION key again will display the audio gain (see Figure 3-10).

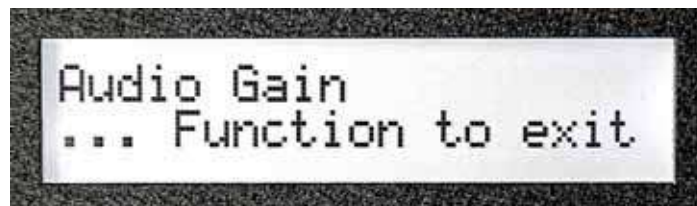

Figure 3-10. Press the FUNCTION Key to read Audio Gain

3. Pressing the FUNCTION key again will display the power output (volts multiplied by amps; see Figure 3-11).

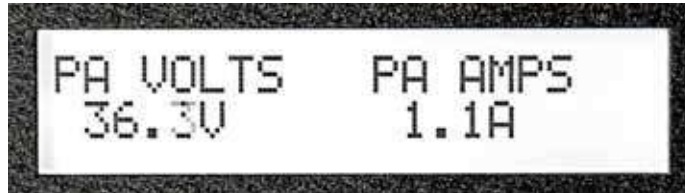

Figure 3-11. Press the FUNCTION Key to read VOLTS & AMPS

4. Pressing the FUNCTION key again results in a screen showing forward power and reverse power (see Figure 3-12).

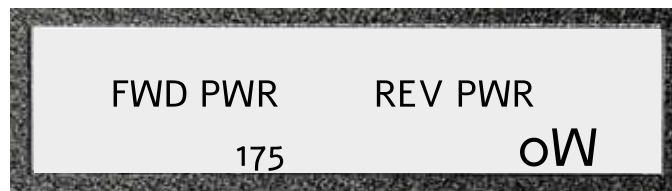

Figure 3-12. Press the FUNCTION Key to read Forward & Reverse Power

5. A final pressing of the FUNCTION key will produce a screen showing deviation (see Figure 3-13).

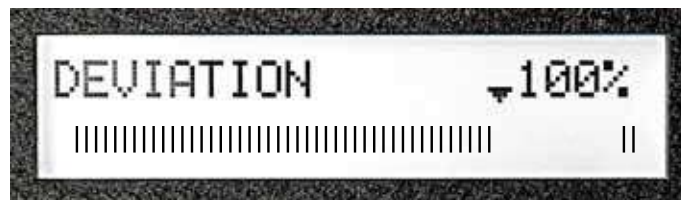

Figure 3-13. Press the FUNCTION Key to read Deviation

As already noted, further pressing of the FUNCTION key will rotate the LCD display through a queue of the same screens.

3.4 Additional Adjustments - The Transmitter offers additional capabilities by pressing the LOWER, RAISE, and FUNCTION keys simultaneously (see Figure 3-14).

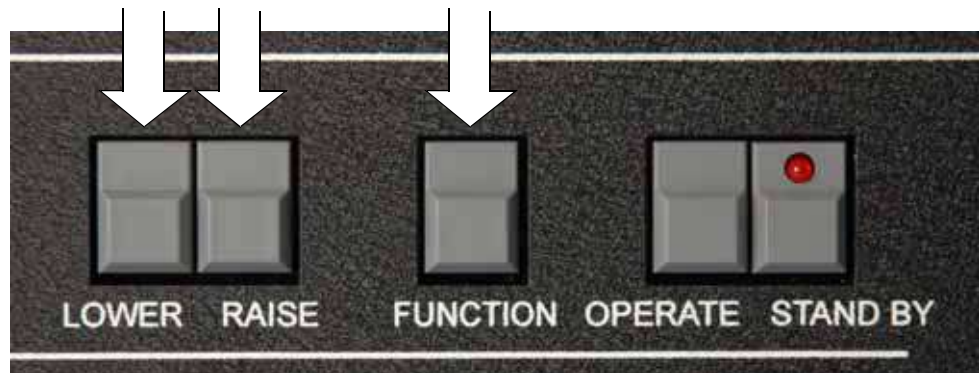

Figure 3-14 Press LOWER/RAISE/FUNCTION Keys Simultaneously



Note: When pressing LOWER, RAISE, and FUNCTION, the Transmitter cannot be in STANDBY mode.

The resulting LCD screens will appear as follows:

1. First,

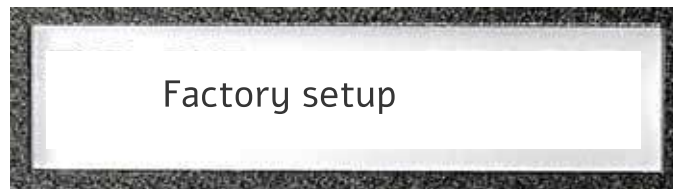

Figure 3-15

After a few seconds, _____

Press the FUNCTION key to display the next LCD screen.

Caution do not change any of these setting unless you have the proper test equipment and are able to make the appropriate measurements

2.

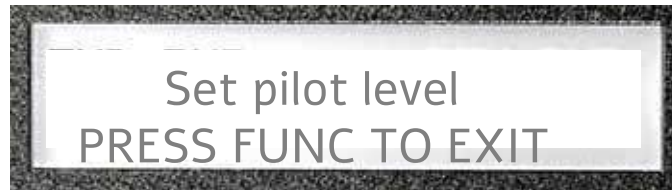

Use the raise Lower Keys to adjust

Figure 3-16

3.

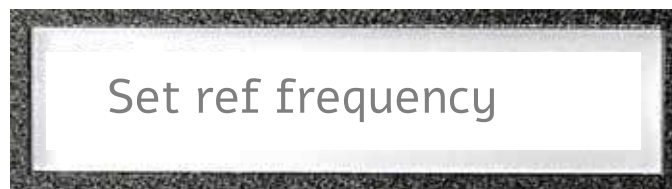

Figure 3-17

4.

3.5 Tune Up the Antenna

After the Transmitter is transmitting on the desired frequency (refer to Section 3.3,

“Getting Started,” on page 3-4), check the reverse power, which should be zero. If the reverse power is higher than 5 percent, recheck the antenna tuning instructions. Anything greater than 5 percent of the forward power (i.e., 5W for a 100W output) requires attention.

3.6 Power Down the System

To power down (turn off) the Transmitter, press the STANDBY key, then disconnect the AC power cord from the AC power socket on the rear panel of the chassis.

Appendix A

Connector Pinouts

This appendix provides connector pinouts and signal descriptions for the user I/O connectors that are installed on the Transmitter rear I/O Panel (see Figure 1-4, page 1-3, in Chapter 1, "Overview and Specifications").

A.1 Accessory Port

The transmitter rear I/O Panel provides a 25-pin male DB25 connector as an accessory-port interface. A pinout is provided in Figure A-1; signal descriptions are defined in Table A-1 on page A-2.

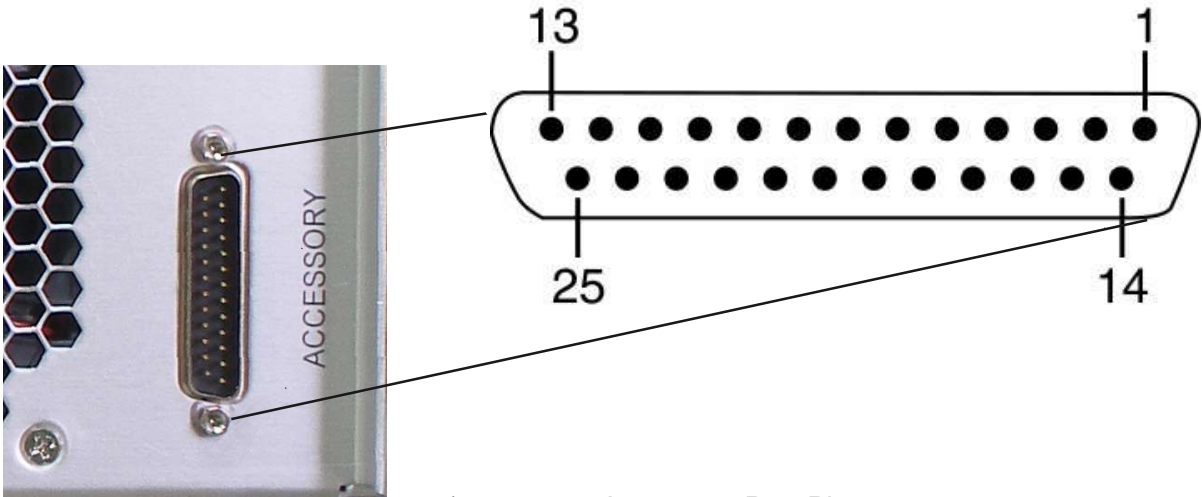

Figure A-1. Accessory Port Pinout

Table A-1. Accessory Port Pinout Signal Descriptions

Pin	Signal Function
1	Forward power DC indication; $2.4V = 150W$
2	Final voltage DC indication; $V = V/10$
3	Output power out of range Hi (10V)
4	Not used
5, 6, 18, 19	24V outout (fan supply for combiners)
7	Not used
8	Raise; ground to raise the output power
9	Not used
10	Not used
11, 12, 23, 24	Ground
13	Remote on (ground to turn the unit on momentarily only)
14	Reverse power DC indication; $2.4V = 150W$
15	Output power out of range Lo (10V)
16	Not used
17	Not used
20	Lower; ground to lower the output power
21	Final current DC indication; Full scale = 2.5V
22	Not used
25	Remote off (ground to turn the unit off momentarily only)

Appendix B

Rack-Mount Slide Installation

An optional set of two rack-mount slides (left side and right side) is available for all Transmitter systems, and should be ordered at the time of purchase. The FM500E S chassis contains two (2) threaded screw holes (see FigureB-1 on pageB-2) on each side to accommodate #10-32 size screws (included with the rack-mount slide kit).

Dimensions of the screw-hole patterns on the sides of the Transmitter chassis for installing rack-mount slides are shown in Figure B-2 on page B-3. The required holes for specialized steel or aluminum slides will have to be measured, drilled, and tapped before installation.



Caution: Any screws used to mount a slide to a Transmitter chassis must not exceed a length of 3/8" to prevent excessive penetration of the chassis.

The rack-mount slide installation kit includes the following items:

- a. Two inside slide sections
- b. Two outside slide sections
- c. Two front (short) slide brackets
- d. Two rear (long) slide brackets
- e. Assorted screws, washers, and nuts

Follow these steps to install a steel rack-mount slide to the Transmitter chassis:

1. Attach the inside slide section (see Figure B-3 on page B-3) to both sides of the transmitter chassis using two #10-32 screws per side (see .
2. Measure the depth of the 19" equipment rack into which the transmitter system will be installed (this can vary from 24" to 30").
3. Using the depth of the e quipment rack, adjust and attach the front and rear slide brackets to the outside slide section using the screws, washers, and nuts provided with the slide kit.
4. With all slide brackets securely attached to both the right and left outside slide sections, install both sections to the insi de right and inside left of a 19" rack with two bolts per bracket , making sure there is ad equate room for the 2RU height (3.5") of a transmitter system.
5. Carefully insert the transmitter system in to the 19" rack so that the inside slides on both sides of the chassis travelsmoothly into the channels of the out-side slide sections. Push the system into the rack until the mounting brackets on the front of the chassis are flush with the front of the rack.
6. Secure the transmitter system to the 19"rack with two bolts on each side.

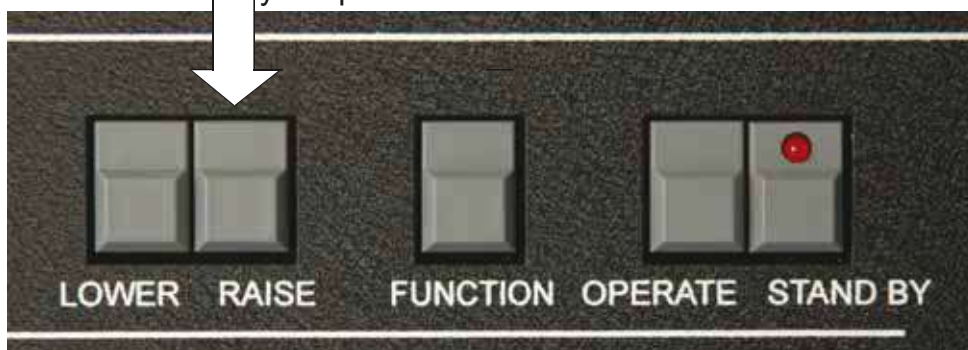

Figure B-1. Transmitter Right-Side Rack-Mount Slide Holes

Appendix C Setting the FSK ID

With the unit in the stand-by mode
Press and hold the Raise button; then switch the unit from

Stand-by to operate **FSK ID TIMER**



Release the Button when this is displayed
on the LCD display



Pressing the Function Button will increment the cursor, pressing raise/lower will change the character. When you are satisfied with both the CW ID and the interval timer (which is in Minutes) press the function switch to bring the cursor to the first character then turn the unit to stand-by.

To disable the CW ID set the timer to 00.

After this is programmed the unit will send the set CW ID at the programmed timer interval. With most FM receivers this id will be inaudible.