

SubAudible Tone Decoder Model Sub-03f

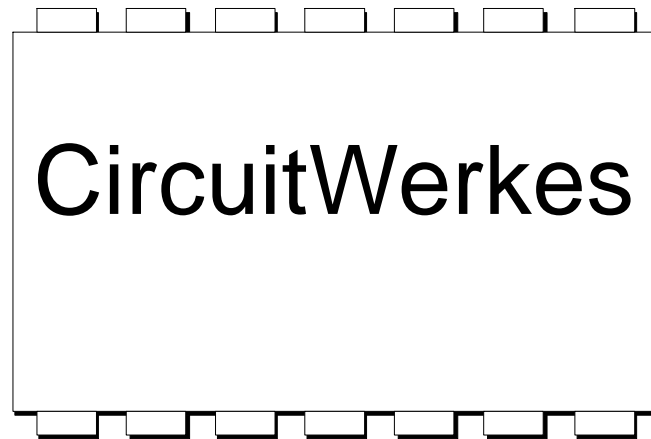

Technical Manual

CircuitWerkes, Inc.
2805 NW 6th Street · Gainesville, FL 32609
(352) 335-6555 · Fax (352) 380-0230
<http://www.circuitwerkes.com>
e-mail: info@circuitwerkes.com

Last revision: January 06, 2004

© 1995-2004 CircuitWerkes All Rights Reserved. All information contained within is proprietary.
No part of this manual may be reproduced or copied without the express written consent of CircuitWerkes.

Notes:

The CircuitWerkes Subaudible Tone Decoder

Description

The CircuitWerkes Subaudible Tone Decoder provides a reliable and accurate solution for decoding subaudible tones from satellite, automation, or other sources of audio. The unit has dry relay contacts and an LED indicator for each of the standard three subaudible signals, 25HZ, 35Hz and the Combination of 25HZ and 35Hz. Alternately, the Sub-03 may be ordered set for 50/75Hz tones. The audio input can accept balanced or unbalanced audio at input levels of -20dBm to +8dBm. The output is balanced, transformerless, and is easily capable of driving a 600 ohm load. Subaudible tones are typically attenuated by 30 to 40dB at the audio output and it is short-circuit protected.

Installation & Setup

CONNECTIONS:

Connections to the subaudible tone decoder are fairly straight forward. Your audio passes through the decoder via the Audio In and Audio Out jacks. When the input is unbalanced, the (-) input lead must be tied to ground. Relay outputs and the power input are brought out to both barrier strips and a Db-9 connector. All relay outputs are separate and operate whenever their specific tone is detected. Two additional barrier strip positions are for the relay disable function. These inputs are active if Jumper J4 is removed. When J4 is removed and there is nothing connected between the disable inputs, the decoder will not output any closures. This is useful if you want your automation or other external timer to activate the decoder only at certain times of the day. If J4 is removed, the Sub-03 must have a connection between these two positions for it to output contact closures. J4 simply parallels the external input connector. If J4 is on (the default) the Sub-03 relays will operate whenever a tone is detected. Finally, in addition to the terminal and Db-9 locations, the power input may be also be made to a 2.5mm coaxial (or "barrel") connector. Both of the power connectors are in parallel with each other, so only one power source at a time can be connected to the Sub-03. See page 3 for connection details. Power is provided by the included "wall-wart." Optionally, the decoder can be powered with any supply of 18-24 Volts AC or DC capable of delivering 150mA. The relay outputs are dry N.O. contacts capable of switching loads up to 10 watts. We recommend slave relays if you intend to switch heavy loads or high voltages.

Important Note regarding program content...

If your subaudible tone decoder is connected to a source that delivers more than one program and one or more of the programs delivered does not contain subaudible tone signalling you may encounter (easily resolved) problems. Any program that does NOT contain subaudible signalling tones probably DOES have subaudible content. Normal music/voice and background noise can easily set off your decoder's outputs if the audio is not (high pass) filtered. Programs that do contain subaudible signalling tones should always be prefiltered at their origination point before subaudible tones are injected, thus keeping the natural low frequency content of normal voice and noise from false tripping decoders down the line.

A good example would be an SCPC satellite receiver that you use for a couple of different network feeds. One of the networks uses subaudible tone signalling for starting local breaks, the other uses DTMF Tones. The network that uses DTMF tones probably does not filter out the subaudible portion of their program audio. If you have a limited number of inputs on your console or automation system, you may not wish to take up two inputs with audio from one source. To help solve this problem, the CircuitWerkes Subaudible Tone Decoder features a disable input. Removing J4 and connecting this line to the decoder's ground will enable the relays. You may connect this line and the decoder's ground to a timed automation output that will sink to ground only during the program whose tones you want to use. Any other time, the automation would unsink the disable input and the tones will not cause relay closures. *If you remove J4 & decide not to use the disable function, a wire jumper must be installed between the two screw terminals to enable the decoder.*

SETTING LEVELS:

The Sub-03 can accept a wide variety of input levels and its improved output driver can supply peak levels of up to +18dBm into a 600 Ohm load. The input level control should be set as high as possible (maximum amount of input audio) WITHOUT lighting the input clipping LED. The Sub-03 has a maximum dynamic range of about 90dB. By setting the highest input level that does not cause overload of the input stage, you are getting the maximum signal to noise ratio from the Sub-03. Note: It is very important to not light the input overload LED or detection of subaudible tones may be adversely affected! Typically, the Input Presence LED will be lit 50-70% of the time. The Input Presence LED should always be "on" during a subaudible tone. This is the correct level range for the tone detectors to work. Finally, adjust the output level control for the level that you want. This control is variable from 0 to about +18dBm. Be sure that the output clipping indicator does not light, or you will have a distorted output.

Sub-03 Connector & Controls Layout (Top View)

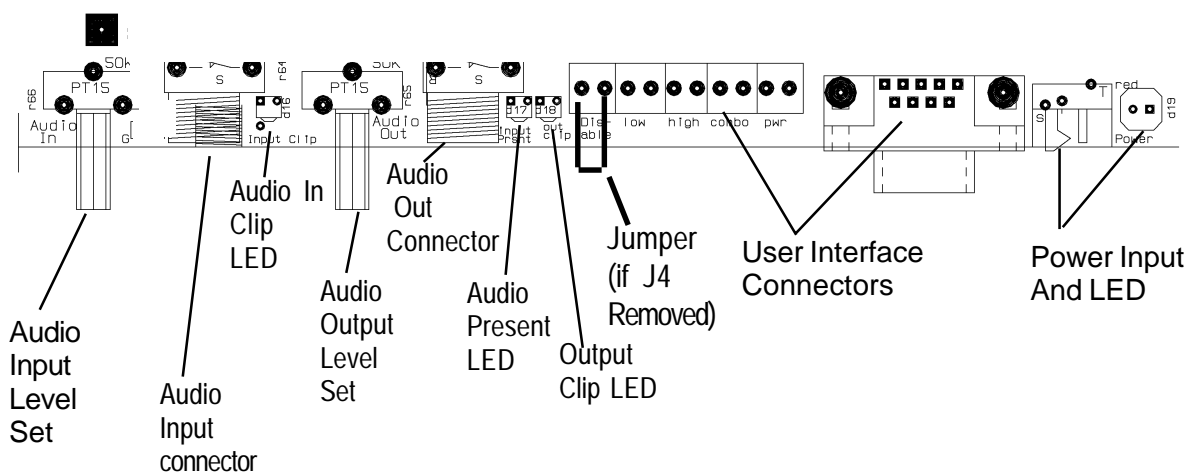

Note: The front panel of the Sub-03 contains a bi-colored LED for indicating 25/35 Hz detection and a single LED for indicating the combination tone.

Sub-03 Db-9 as seen looking at front of device.

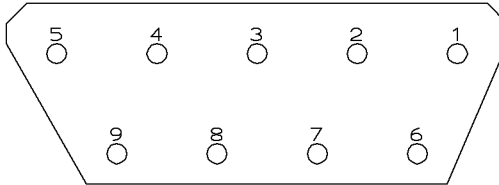

LEGEND:

- 1 & 6 =
- 3 & 7 = Low Tone Relay Output
- 4 & 8 = High Tone Relay Output
- 5 & 9 = Combo Tone Relay Output

Connections on the Db-9 parallel those on the screw terminals.

CircuitWerkes Sub-3 Subaudible Tone Decoder Audio In/Out Wiring

Input

1/4" TRS (phone) PLUG

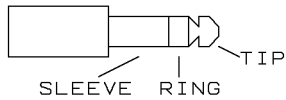

Tip is Balanced (or Unbalanced) + In
Ring is Balanced - in.
Sleeve is audio ground and should be connected to your source's ground.

If your input is unbalanced you must tie ring and sleeve together for proper operation.

Output

1/4" TRS (phone) PLUG

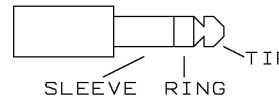

Tip is Balanced Out +.
Ring is Blanced Out -.
Sleeve is left floating and may be tied to ground on the other end.

Do NOT Connect minus (-) Output to Ground!

Size	Document Number	REV
A		
Date:	April 6, 1995	Sheet of

SUB-3 PC Board Layout

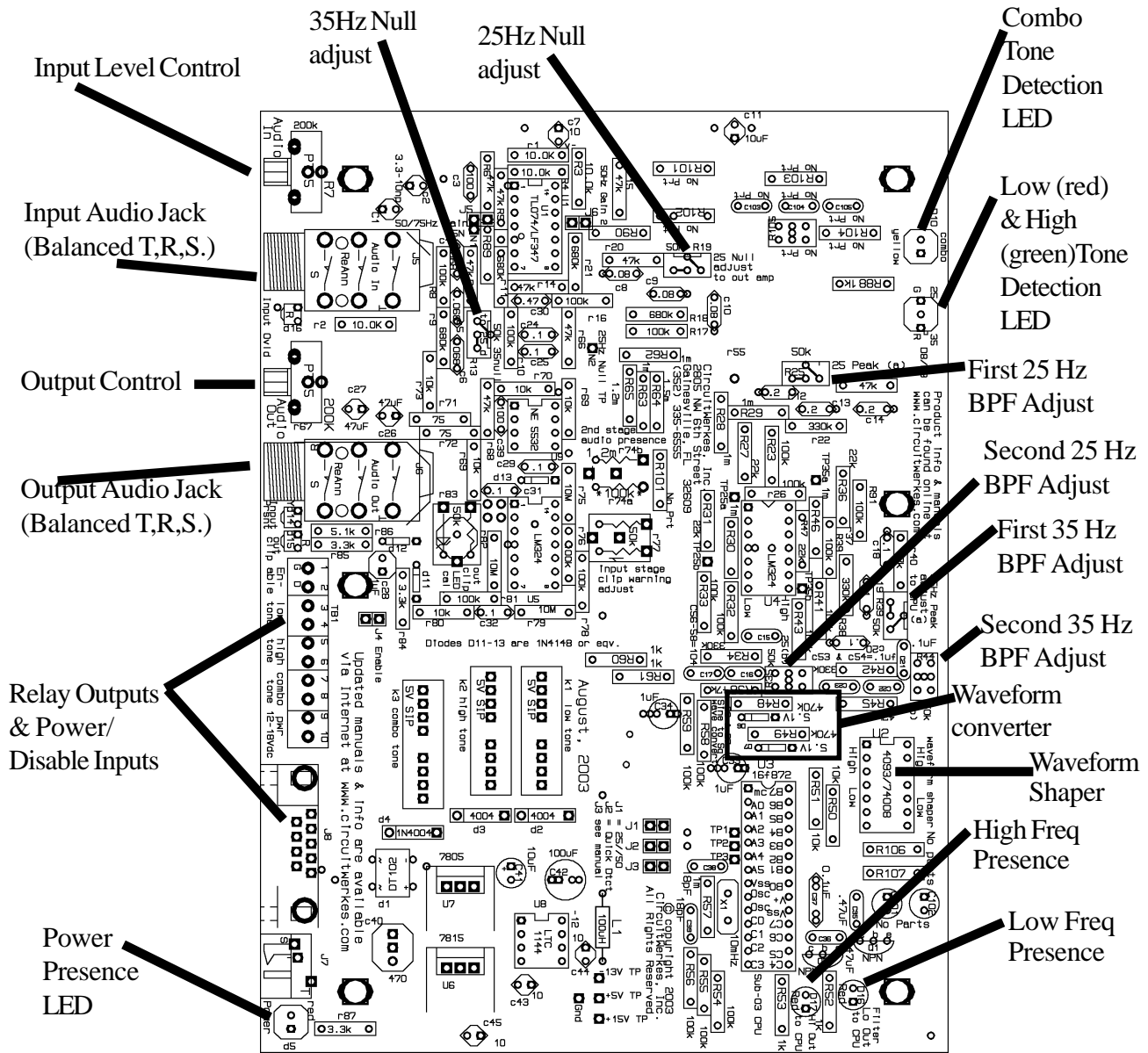

Jumper Functions:

J1= 25-35 Hz detect when "on" or 50/75 Hz detect when "off". Note that retuning of all six filters is required to detect an alternate frequency.

J2= Normal or fast detect. When "on" the SUB-03 detects tones in about 200 to 350 milliseconds. When off, tones are detected in 100 to 200 milliseconds. Typical response is 250 milliseconds for normal mode and 100 milliseconds for fast mode. The combo tone output cannot be used in fast response mode.

J3 = reserved for future use but the jumper must be left "on" for the SUB-03 to produce relay outputs

J4 = Enable bypass. When on, enables the relay outputs. When off relay outputs are disabled unless the enable input is grounded

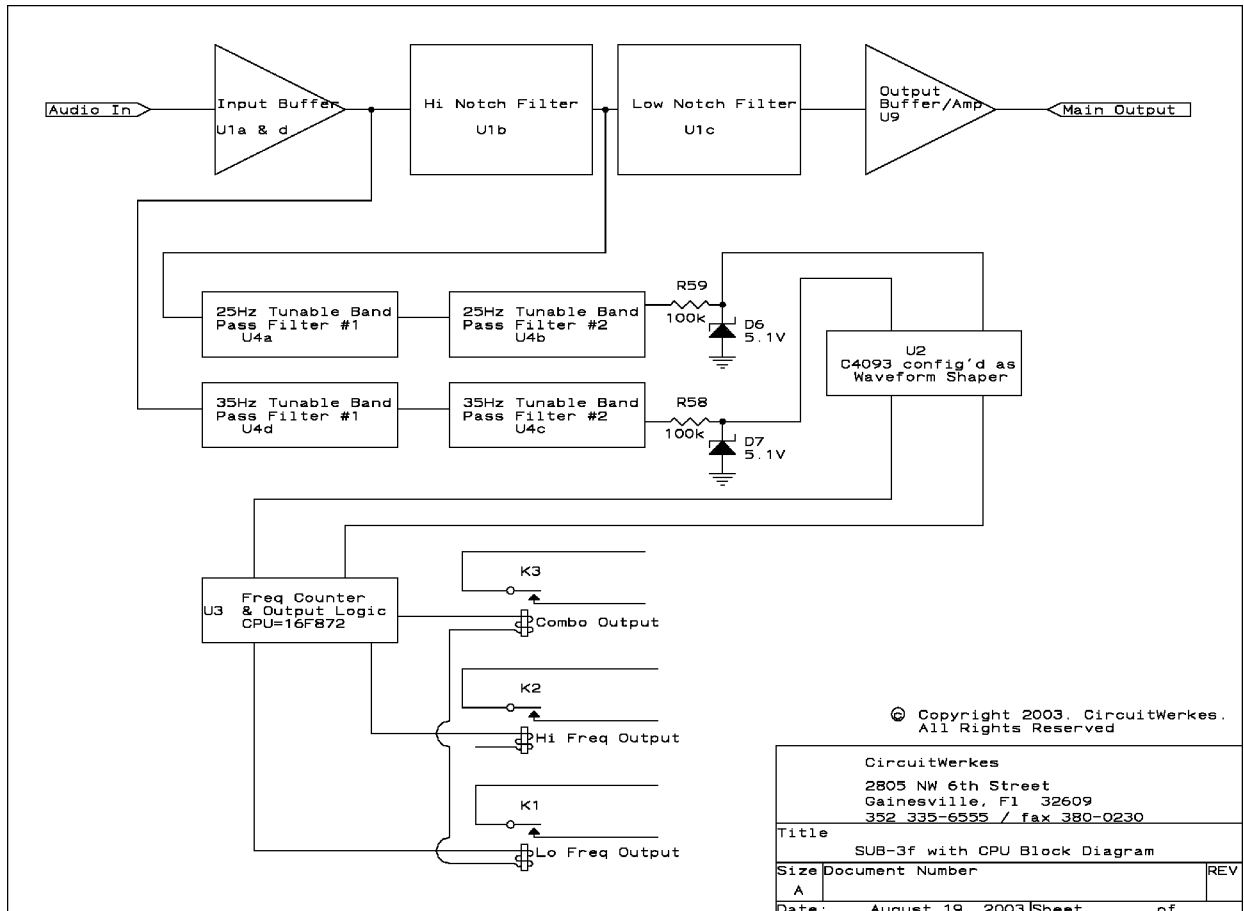

Theory of Operation

Incoming audio is buffered and level controlled by U1a & d and associated components. Three nodes are fed by this first buffer section, the audio input clipping indicator (U5c), the input audio presence indicator (U5d), the 35Hz notch section (U1b) and the main 35Hz bandpass section, U4d & c. The audio input clipping and presence indicators are basically identical except that the clipping indicator is driven directly from the first buffer's output and is set to a level just below the point where the input level can cause overload of the CPU resulting in possible failure to detect tones. The audio presence indicator is fed from just after the input gain control pot and is comprised of opamp U5c (operated as a comparator), reference-set resistors r74a & r74b, a yellow or green LED and associated components. When the audio level exceeds the preset comparator reference level, the comparator changes states and illuminated the LED. The reference level voltage divider is set to illuminate the LED when detection amplitude is minimal for correct detection of tones. We recommend setting the input about 6dB higher than the minimum necessary to light the LED.

The 35Hz and 25Hz notch filters are tunable from below 20Hz to around 100Hz. The exact center frequency of which is set by multiturn pots R13 for 35Hz and r19 for 25Hz. Front-end filtering for the frequency detector is provided by U4. Each amplifier section of U4 has an associated tunable Bandpass filter. Two filters are cascaded for the low frequency and two are used for the high frequency. When valid subaudible tones are present, the outputs of each filter are typically (nearly) square waves approaching rail-to-rail levels. Because high Q bandpass filters are used, the filter outputs pass very little except the tuned frequency. A benefit of this effect is that the SUB-03 is virtually immune to noise caused by program material and will reliably detect subaudible tones that are embedded in program streams. The filters' pseudo-square wave outputs are fed to 5.1V zener diodes D6 & D7 which square up the BPF outputs and convert them to 5V logic levels. These signals are then fed to U2, a quad, schmidt-triggered, NAND gate. Two gates are cascaded for each frequency. These gates act as waveform shapers and buffers. Two LEDs are driven from the output of these gates to indicate the presence of high and low freq tones. When audio input levels are ideal, these LEDs will only light during the presence of the correct tone, however, in the presence of high, but still acceptable levels, it is not unusual for the LEDs to light erroneously. Therefore, the outputs of the NAND gates are sent to a CPU which acts as a frequency counter and filter. A fairly complex series of tests are performed by the CPU to validate the inputs and determine which frequency is present. Even if there is noise on a gate's output, the CPU will only produce an output if its input is at the correct frequency. Because we use actual frequency detection, the input amplitude has much less effect on correct detection than in some other makes of subaudible decoders. The CPU directly drives each output relay.

Field Alignment Procedure:

Test Equipment needed:

A) Signal generator capable of producing sine waves of the correct frequencies (low freq, high freq and combination of low and high freq) such as a Berkely Nucleonics Corp. model 625 or equivalent. If an audio signal generator is not available, the output of a PC audio card can be used with a suitable wav file looped for each test. Shareware programs such as Cooledit96 are adequate for the task of looping file segments to produce continuous test tones. The CircuitWerkes website has a pre-made test file for 25Hz, 35Hz and combo tones that can be downloaded.

B) An audio test set capable of measuring signals from at least +20 to -60 dBm (HP 3551a, HP3555B, Potomac AT-51 or equiv).

C) {Preferred Optional} Any single or dual channel oscilloscope capable of measuring audio frequencies.

Connect the BNC 625 signal generator to the audio input of the SUB-03.

Jumpers should be set as follows: J1=on, J2=on, J3=on, J4=on

Connect SUB-03 Output to Audio Test Set & turn it on. Set it for 0dBm range.

Turn on BNC625 & set it to memory zero (1kHz @ 0dBm)

Set SUB3 input pot to about 10 o'clock; set output to 2 o'clock.

Plug power connector in and verify that you hear clean audio on the test set. **If you do not hear clean audio or any of the following items is warm, disconnect power immediately:** D1(bridge), C40 (470uF cap), U8(LTC-1144), U6(7815), U7(7805), C4, c10 or c15. Verify that all ICs are aligned with the SILKSCREEN on the PC Board, not just the notch in the socket.

Set signal generator to **25Hz** at 0dBm.

Adjust the "25Hz null adjust to output amp" potentiometer for minimum reading on the audio test set. The null should occur between -20dBm and -50dBm.

Set signal generator to **35Hz** at 0dBm.

Adjust the "35Hz null" potentiometer (R13) for minimum reading on the audio test set. You will have to adjust the range to -20 or lower as you adjust the null potentiometer.

Turn on the oscilloscope and set channel one of the scope so that it can display AC waveforms of 25Hz to 35Hz with an amplitude of .5 to 10V.

Disconnect the input audio and connect the probe to test point "TP35a".

If you see a square wave on the scope, the filter is oscillating. Reconnect the 35Hz test tone audio and adjust 35Hz Peak Adjust (a) for a sinewave output at its peak amplitude. This adjustment should not produce a square wave at any time, but clipping of the waveform at the tops and bottoms of the peaks is okay. Reduce the signal generator's output by 20dB and connect the probe to test point "TP35b".

Adjust 35Hz trimmer "(b)" for a sinewave of maximum amplitude without producing a squarewave. If you do get a squarewave, remove the audio input from the SUB-03. If the squarewave persists, then the filter is oscillating and must be adjusted until it stops. If the squarewave disappears when the input is removed, then turn the signal generator's output down until you get a sinewave again.

Continue to Adjust the sinewave until you get maximum amplitude.

With a sinewave showing on test point "TP35b", readjust both the 35Hz (a) and (b) trimmers for maximum amplitude.

Observe the LED marked "Hi Out to CPU". It should be on. You should also note the red 35Hz LED (d9) is illuminated at the front of the board.

Set your signal generator for 25Hz at 0dBm and connect the scope probe to test point "TP25a".

If you see a square wave on the scope, the filter is oscillating. Adjust "25 Peak (a)" for a sinewave output at its peak amplitude. This adjustment should not produce a square wave at any time.

Set your signal generator for 25Hz at 0dBm and connect the scope probe to test point "TP25b".

Adjust trimmer "25(b)" for a sinewave of maximum amplitude without producing a squarewave. If you do get a squarewave, remove the audio input from the SUB-03. If the squarewave persists, then the filter is oscillating and can be adjusted until it stops. If the squarewave disappears when the input is removed, then turn the audio generator's output down until you get a sinewave again and continue to Adjust the sinewave until you get maximum amplitude.

With a sinewave showing on test point "TP25b", adjust both the 25Hz (a) and (b) trimmers for maximum amplitude.

Observe the LED marked "Filter Lo Out to CPU". It should be on. You should also note the Green 25Hz LED (d8) is illuminated at the front of the board.

Set your audio generator to produce dual tones; 25 & 35Hz at -20dBm. Note that the yellow combo-tone LED (D10) lights up.

Set your signal generator for 1kHz at +6dBm and set the audio tester to the +20dBm range.

Adjust the audio output until the level reaches +16dBm (-4dBm on the +20 scale).

Adjust r83, the "Out Clip LED Cal" until the output clip LED just begins to illuminate.

Set your signal generator for 1kHz at -10dBm and adjust the input level control (R7) until the green/yellow Audio presence LED is just illuminated.

Set the audio tester to the -10dBm range and adjust the output control for a reading of 0dBm.

Set your signal generator for 1kHz at -10dBm & Adjust the input level control (R7) until the green/yellow Audio presence LED is just illuminated.

Alignment is complete.

REPAIR OR SERVICE INFORMATION

In the event of the need for service or repair, call CircuitWerkes at (352) 335-6555 for a Return Merchandise Authorization number (RMA). Then carefully package the unit along with a note of the problem and send it to the address below. Clearly indicate the RMA number on the outside of the box. We cannot accept returns without an RMA. Be sure to include your address (not a PO box), telephone number and best time to call.

CircuitWerkes

ATTN: CUSTOMER SERVICE DEPT.
2805 NW 6th Street
GAINESVILLE, FL 32609

<p style="text-align: center;">CircuitWerkes Limited Warranty</p> <p>This product is warranted against defects for two years from date of purchase from CircuitWerkes and CircuitWerkes authorized distributors. Within this period, we will repair it without charge for parts and labor. Proof of purchase-date required. Warranty does not cover transportation costs, or a product subjected to misuse, accidental damage, alteration (except as authorized by CircuitWerkes), improper installation, or consequential damages.</p> <p>Except as provided herein, CircuitWerkes makes no warranties, express or implied, including warranties of merchantability and fitness for a particular purpose. Some states do not permit limitation or exclusion of implied warranties; therefore, the aforesaid limitation(s) or exclusion(s) may not apply to the purchaser. This warranty gives you specific legal rights and you may also have other rights which vary from state to state.</p>

Note: Manuals are frequently updated in order to improve them. The latest version of this manual is available on-line at the CircuitWerkes Internet web site. The address is: <http://www.circuitwerkes.com/>
E-mail may be sent to info@circuitwerkes.com.